

The Neatform Benefit

– saves fabrication time and improves product quality.

After you have experienced the consistent thickness, regularity and ultra smooth surface of Neatform Bendy MDF, you won't want to work with bending plywood alone ever again.

We have compiled this information sheet to help you get the best from Neatform Bendy MDF. It contains the following:

- Introduction to Neatform
- Neatform Specification
- Frequently Asked Questions
- Fabrication
 - Techniques
 - Methods
 - Tips

Frequently asked questions

Q: What is the biggest saving?

A: Fabricating time is the biggest saving because of Neatform's consistent thickness and regularity.

Q: What are the other benefits of using Neatform?

A: The ultra smooth surface and consistent "bendability" of Neatform makes it very fast and easy to work with.

Q: Does Neatform offer new design opportunities?

A: Yes - a complete range of new fabrication techniques will help fabricators satisfy designers' expectations in a practical way.

Q: Can I create a curved surface that retains its shape?

A: Yes – This is one of the fantastic design and fabrication opportunities offered by Neatform. For further information have a look at the section on fabrication techniques and fabrication methods.

Q: Is Neatform easy to work with?

A: Yes – either attach to a framework, glue two pieces together using the double skin technique or combine with other materials such as bending plywood – to provide the Neatform surface, ready to finish. We suggest you read the section on fabrication techniques for further information.

Q: Can Neatform be surfaced?

A: Yes – Neatform can be surfaced before or after fabrication. See the paragraph on surfacing in the Section on Fabrication Tips.

Q: Do I need any special equipment to work with Neatform?

A: No – Expensive presses are not required. Only normal woodworking tools are required.

Q: Can I use a vacuum press?

A: Yes – a vacuum press is a great method for working with Neatform.

Q: What is the minimum bend radius?

A: Typically 150 mm using 6 mm Nominal Neatform, although it is very supple and will bend to a tighter curve. We suggest you read the section on Bending Capabilities and test a small section before proceeding with your main project.

Q: What is the advantage over bending plywood?

A: "Surface quality, dimensional accuracy and stability, easy finishing and low odour." For further information we suggest you visit Neatform v. Bending Plywood on our Web Site www.neatconcepts.com

Q: Can Neatform be painted?

A: Yes – the smooth MDF surface is ideal for painting.

Q: Can Neatform be combined with other materials?

A: Yes. Neatform can be combined with a variety of other bendable materials including bending plywood, veneer and laminate.

Fabrication Techniques

Framing Techniques

1. Single Skin Method

Description

Single skin of Neatform attached to a framework.

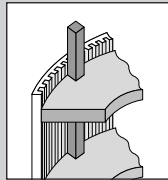

Example Applications

Used in applications where light-weight is an advantage, such as exhibition cabinets, columns, displays, wavy walls, ceilings, stage and film sets.

Features & Benefits

- Fast fabrication
- Fast finishing
- Light-weight
- 6 mm or 9 mm thick

2. Multi Skin Method

Description

Two or more skins of Neatform attached to a framework.

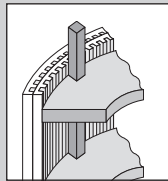

Example Applications

Used in applications where medium weight or thicker sections are required

Features & Benefits

- Fast to fabricate
- Thickness upwards from 12 mm + surfacing materials
- Medium to heavyweight

3. Surfacing Method

Description

Single skin of Neatform used to surface bending plywood previously attached to a framework.

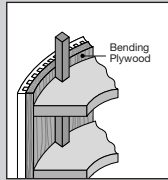

Example Applications

Improves conventional fabrication methods by eliminating the problems associated with the poor surface and inconsistency of bending plywood.

Features & Benefits

- Fast to fabricate
- 12 mm to 18 mm thick + surfacing materials
- Hides the poor surface, cracks and exclusions in bending plywood
- Surface ready for finishing
- Screw and hinge holding

Frameless Techniques

1. Combination Method

Description

Single skin of Neatform combined with laminate or phenolic backed veneer to create free-standing curved shapes.

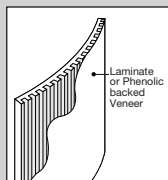

Example Applications

This method does not use a framework, so it can be used to create double-sided structures with visual impact. *Applications include* lightweight screens, display panels, graphics panels, stage and film sets.

Features & Benefits

- Free-standing curved shapes
- Light-weight
- Show surfaces on both sides
- 6 mm or 9 mm thick + surfacing materials

2. Double Skin Method

Description

Two skins of Neatform glued together to form double sided free standing curved shapes.

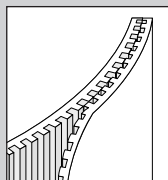

Example Applications

For fabricators who mainly work with bending plywood, the Neatform double skin technique offers fantastic design and fabrication opportunities, whilst saving substantial amounts of time during fabrication and finishing. *Applications include* reception counters, display units, columns, screens, display panels, stage and film sets.

Features & Benefits

- Medium weight
- Free-standing curved shapes
- Show surfaces on both sides
- 12 mm or 18 mm thick + surfacing materials

3. Sandwich Method

Description

One skin of Neatform either side of bending plywood – to create solid free standing curved shapes.

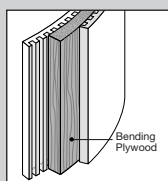

Example Applications

Used on more structural applications including: cabinet doors, drawer fronts and decorative walls, kick boards. This method is particularly good when screw and hinge holding is required.

Features & Benefits

- Heavy- weight applications
- 18 mm to 27 mm thick + surfacing materials
- Screw and hinge holding

Fabrication Methods

Framing Techniques

Single Skin Method – Directions

1. Fabricate a framework with sufficient shaped and supporting ribs to support a single skin of Neatform. For example – curved ribs would typically be set at 350 mm to 450 mm centres.
2. Straight ribs used to support the curved ribs should be set-back from the face of the curved ribs to ensure they do not interfere with the Neatform.
3. Cut the Neatform to rough shape and offer up to the framework to ensure a good fit. Position the Neatform grooved face inwards unless making a feature of the grooved surface.
4. Apply a good coat of wood glue to mating surfaces on the framework and Neatform, and finally position, while noting that it is not necessary for the Neatform grooves to be filled with glue. A paint roller is an ideal tool for this job.
5. Either tack into position with hot melt adhesive if access to the back face is available, or staple – see fabrication tips.
6. Trim to shape and finish in the normal way.

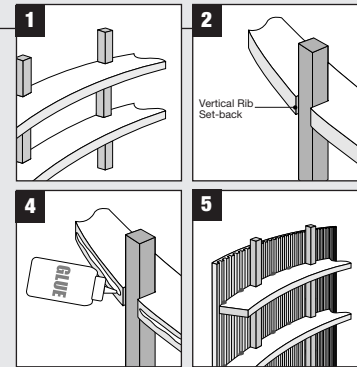

Multi Skin Method – Directions

1. Fabricate a framework and apply the first layer of Neatform as described for the single skin method.
2. To apply the second and subsequent skins of Neatform cut to rough shape and offer up to the surfaced framework to ensure a good fit, positioning the Neatform grooved face inwards.
3. Apply a good coat of adhesive to mating surfaces, and finally position, while noting that it is not necessary for the Neatform grooves to be filled with glue. A paint roller is ideal for this job.
4. Hold in position with either a clamp strap or sufficient staples to retain the shape until the adhesive holds, whilst noting that this may not be necessary with some contact adhesives.
5. When sufficient layers have been added trim to shape and finish in the normal way.

Surfacing Method – Directions

1. Fabricate a framework and cover with bending plywood using conventional techniques.
2. Cut the Neatform to rough shape and offer up to the framework to ensure a good fit, positioning the Neatform grooved face inwards unless making a feature of the grooved surface.
3. Following the glue manufacturer instructions, apply a coat of wood glue or contact adhesive to the Neatform and bending plywood and finally position. If contact adhesive is used it is essential to ensure correct positioning is achieved first time because subsequent adjustment will be impossible.
4. Hold in position with clamps while wood glue cures. Optionally, staples can be used to pin in position, while the adhesive cures. For further information on stapling see the section on fabrication tips.
5. Trim to shape and finish in the normal way.

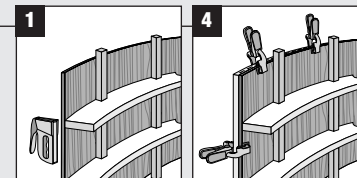

Fabrication Methods

Frameless Techniques

Combination Method – Directions

1. To create a curved surface using the Combination Method, first bend the piece of Neatform and the surfacing material to the approximate shape (Neatform grooved face to surfacing material), and roughly cut to size.
2. Lay both sheets flat (Neatform - grooved face upwards) and apply a good even coating of wood glue to the surface of both sheets, while noting that it is not necessary for the Neatform grooves to be filled with glue. A paint roller is an ideal tool for this job. *Please note – contact adhesive should not be used with this method.*
3. Place the sheet of Neatform and the surfacing material together and bend to the finished shape.
4. While the glue is still wet, clamp into shape, applying moderate pressure, to both faces to ensure a good bond, and leave to set. Follow the adhesive manufacturer's guidance on curing times.
5. When released, Neatform and the surfacing material will retain their shape, ready for trimming and finishing.

Double Skin Method – Directions

1. To create a free-standing curved shape with Neatform Bendy MDF, first bend two pieces of Neatform to the approximate shape (grooved face to grooved face), and roughly cut to size.
2. Lay both sheets flat (grooved face upwards) and apply a good even coating of wood glue to the surface of both sheets, while noting that it is not necessary for the Neatform grooves to be filled with glue. A paint roller is an ideal tool for this job. *Please note – contact adhesive should not be used with this method.*
3. Place the two sheets of glued Neatform together and bend to the finished shape. **DO NOT ATTEMPT TO INTERLOCK THE GROOVES**
4. While the glue is still wet, clamp into shape, applying moderate pressure to both faces to ensure a good bond, and leave to set. Follow the adhesive manufacturer's guidance on curing times.
5. When released the resulting Neatform structure will retain its shape, ready for trimming and finishing.

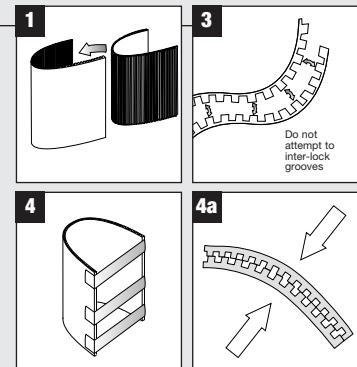

Sandwich Method – Directions

1. To create a free standing curved surface with Neatform Bendy MDF and bending plywood, first bend the two pieces of Neatform and one piece of bending plywood to the approximate shape, and roughly cut to size. Please note that the grooved faces on the Neatform face each other.
2. Apply a good even coating of wood glue to the mating surfaces of all three sheets, while noting that it is not necessary for the Neatform grooves to be filled with glue. A paint roller is an ideal tool for this job. *Please note – contact adhesive should not be used with this method.*
3. Sandwich the bending plywood between the two sheets of glued Neatform and bend to the finished shape.
4. While the glue is still wet, clamp into shape, applying moderate pressure, normal to both faces to ensure a good bond, and leave to set. Follow the adhesive manufacturer's guidance on curing times.
5. When released, Neatform will retain its shape, ready for trimming and finishing.

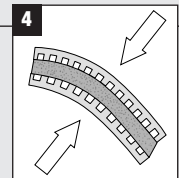

Introduction to Neatform Bendy MDF

Product Introduction

Neatform is a high quality bendable sheet material. It is a processed sheet of MDF, which is widely recommended by architects and designers and used by woodworkers where top quality curved shapes or surfaces are required.

Neatform has a smooth surface, which makes it ideal for painting, veneering or laminating. Combine this with the consistency and dimensional stability of the high quality MDF used to make Neatform, it has become the preferred bendable material for many applications including: columns, counter fronts, wavy walls, ceilings, stage and film sets and commercial cabinet making.

Neatform can be attached directly to a framework or used to surface another material such as bending plywood. Alternatively, using the double skin technique, two sheets of Neatform can be glued together to create freestanding double sided curves, which enable greater design flexibility.

Neatform can be used to fabricate lightweight components. Also, it can be used in conjunction with bending plywood to create components where structure, impact resistance and screw holding ability are important.

Fabrication Tips

Jointing Methods

- Increase the length or width of boards by using a lap joint, sometimes referred to as an offset butt joint.
- H-Section construction strips can be used to join lengths of Neatform. Alternatively, dowels or biscuit joints can be used to create butt joints.

Adhesives

In the majority of fabrication methods wood glue is recommended, particularly on the frameless methods where contact adhesive should not be used because of the flexible glue line.

Wood glues or contact adhesives recommended for use with MDF and any surfacing materials, to be used in conjunction with Neatform, can be used in the frame and surfacing methods. However, as with any product or application, it is best to test a small sample to determine how the adhesive and materials will work together.

When using contact adhesive, enhanced results can be achieved by masking off some sections of mating areas of Neatform and bending plywood for example, and then coating with contact adhesive. When the masking is removed apply a bead of wood glue to the unmasked areas of both surfaces. When the two surfaces are put together an immediate bond is made by the area covered with contact adhesive and after curing, the wood glue bond adds strength with the advantage of the rigid glue line.

Alternatively, structural urethane adhesives can add extra strength in critical areas.

Please note the recommended gluing techniques in 'construction techniques'.

Surfacing

Neatform can be surfaced on the ungrooved side before or after bending with either veneer or laminate. The decision to apply before or after will generally be determined by considering a number of factors such as the bending radius and the type of veneer (e.g paper backed or wood on wood) or the laminate grade. Generally vertical laminate grades are recommended since these are thinner and more flexible.

The benefit of pre-surfacing Neatform before fabrication is the opportunity to use PVA adhesive in conjunction with a flat bed press. The main factor to bear in mind is that the resulting Neatform composite panel takes on at least the stiffness of the stiffest element, which in the case of laminate is generally the laminate.

Edge Finishing

Depending on the application, exposed Neatform edges can be finished with a surfacing material such as a wood lipping, veneer, laminate or other edging material that has been formed to shape and applied with a suitable adhesive. Suitable wood filler can also be used to fill exposed Neatform slots. If in doubt, test a small section before proceeding with the main project.

Stapling

It is advisable to use u-shaped staples, orientated across the Neatform grooves. Staple gun pressure should be lowered to reduce the possibility of blowing through the surface. Stapling without additional adhesive is not recommended unless making a temporary joint.

Screw holding

Neatform is made from thin MDF therefore its screw holding ability is limited. However, when Neatform is used in conjunction with bending plywood (see fabrication techniques), the combination takes advantage of the strength of the plywood and surface quality of Neatform. Because of the wide variety of screw types and applications, it is recommended that users contact their screw supplier for advice.

Hinge holding

There are a wide variety of hinges that can be used with Neatform, when it has been combined with bending plywood to increase strength and screw holding ability. Hinges range from the screw-free "insert type" that use an expanding cup, through other types that have pre-attached expanding dowels to simple screw-on types, which are not recommended. Because of the wide variety of hinge types and applications it is recommended that users contact their hinge supplier for advice.

Neatform Specification

Product Characteristics

Neatform is produced in two versions - 2440 x 1220 mm Long Cut sheets and 1220 x 2440 mm Cross Cut sheets. In both versions the sheet is grooved in one direction so that for example; either a tall column or wide counter-front can be produced. There are un-grooved border edges, approximately 30 mm wide on the two edges running parallel with the grooves. This un-grooved edge protects and makes the product more stable when being handled.

Physical Properties

The standard specification physical properties of the MDF used to manufacture Neatform are:

- Moisture content 5-6%
- Density 750 Kg/m³
- Thickness Tolerance ±0.15 mm

Bending Capabilities

The typical minimum bending radius obtainable using 6 mm Neatform is 150 mm. If a tighter radius is required it is best to test before proceeding, because although Neatform will bend with ease, the grooves may “telegraph”, particularly if excessive pressure is applied to the bend or the material has been badly handled or stored. Bending capabilities of Neatform vary with the moisture content and temperature of the MDF and, because it is manufactured from natural raw materials, it may vary slightly from one batch to another.

Long sections are trickier to fabricate and may require a fixture or second pair of hands to form and secure. As with many products being used for the first time, it is worthwhile planning out a program of work and testing critical areas before proceeding with your main project.

Dimensions and weights

Panel Size	Thickness	Wt./Sheet	Wt./SqM	Pallet Quantity
2440 x 1220 mm (Long Cut)	6 mm	10.6 kg	3.56 kg	60 panels
1220 x 2440 mm (Cross Cut)	6 mm	10.6 kg	3.56 kg	60 panels
2440 x 1220 mm (Long Cut)	9 mm	15.2 kg	4.27 kg	40 panels
1220 x 2440 mm (Cross Cut)	9 mm	15.2 kg	4.27 kg	40 panels

Water & Fire Resistance

Neatform is not made from fire resistant MDF nor is it recommended for wet applications.

Cold Conditions

The bending characteristics of Neatform and other materials such as laminate vary with temperature. Care must be taken, especially in cool conditions, that the materials don't become too brittle to work with.

Temperature Conditioning

Neatform should be acclimatised the same as the surfacing material, adhesives, paints or lacquers to be used. If available refer to the fabrication guidelines for the surfacing material, adhesives, paints or lacquer.

Handling

Care should be taken when handling Neatform Bendy MDF. The size, weight and flexibility of a full sheet will generally require two people to ensure that the material is not over-flexed or broken.

Storage

Neatform should be stored flat in such a way that both surfaces are protected. Store in a dry area and avoid direct contact with the floor.

Health and Safety

When working with any timber based product including MDF it is important to take health and safety seriously. Protective goggles and a dust mask are essential. MDF must be cut in a well-ventilated area and all machining tools should be fitted with dust collection systems. We recommend that you visit the Material Safety Data Section of our web site www.neatconcepts.com